

STOVAX

Fire Your Imagination

Studio 2 NZ

Freestanding Zero Clearance Box



Instructions for Assembly

For use in NZ (New Zealand)

These products are tested in accordance with AS/NZS 4012:1999, AS/NZS 4013:1999 and AS/NZS 2918:2001 and comply with the NZ NES and ECAN emission requirements when using softwood

All installations must be carried out by an S.F.A.I.T (Solid Fuel Authorised Technician).

In New Zealand, the Studio must be bolted to the base to comply with the seismic restraint provisions of AS/NZ 2918:2001

IMPORTANT

THE OUTER CASING, FRONT AND GLASS PANEL BECOME EXTREMELY HOT DURING OPERATION AND WILL RESULT IN SERIOUS INJURY AND BURNS IF TOUCHED. IT IS THEREFORE RECOMMENDED THAT AN APPROVED FIREGUARD IS USED IN THE PRESENCE OF YOUNG CHILDREN, THE ELDERLY OR INFIRM.

CAUTION: THIS APPLIANCE SHOULD BE MAINTAINED AND OPERATED AT ALL TIMES IN ACCORDANCE WITH THESE INSTRUCTIONS.

Keep them in a safe place for future reference and when servicing the fire.

Assembly Instructions

Covering the following model RVFS-2ZCNZ for use with RVST-2HTNZ

1. Studio Freestanding Zero Clearance Box Dimensions - including Cabinet and Heat Shield

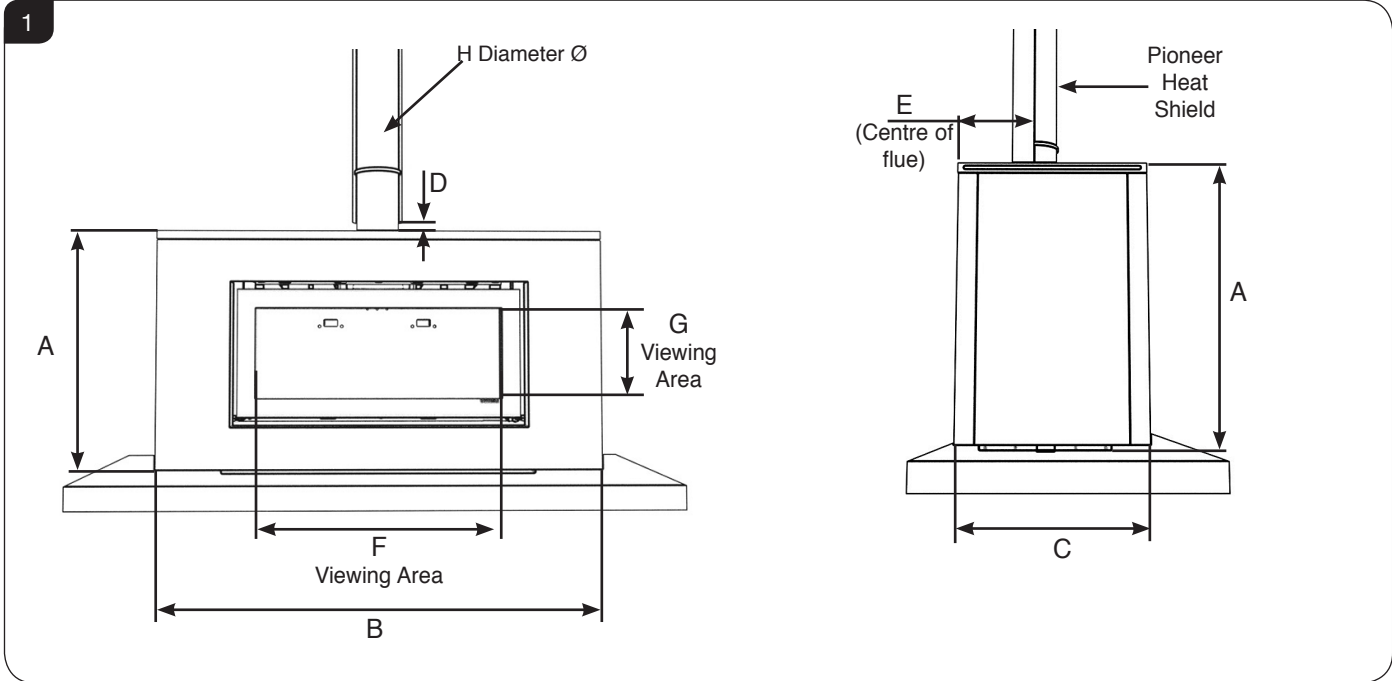

Description	Model	A	B	C	D	E	F	G	H
Studio 2	RVFS-2ZCN	780	1410	515	5	200	790	290	150

All dimensions in mm. (25.4 mm = 1")

2. Cabinet Assembly

2.1 Once the appliance has been bolted to the hearth and the flue system connected and the Pioneer Heat Shield has been fitted as detailed, it is possible to assemble the Freestanding Cabinet, see Diagram 2.

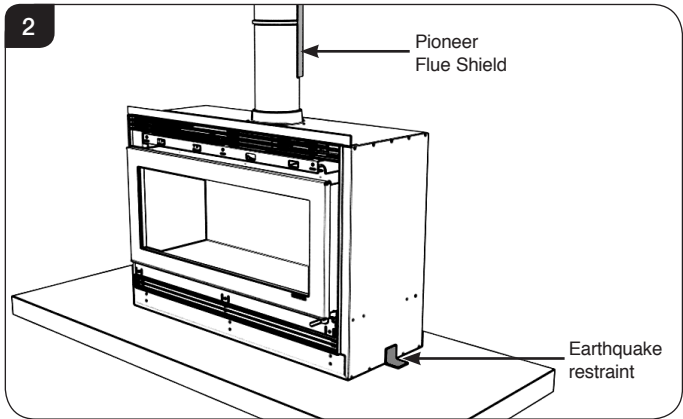

2.2 Place the Top saddle on the top of the Firebox and position centrally, see Diagram 3.

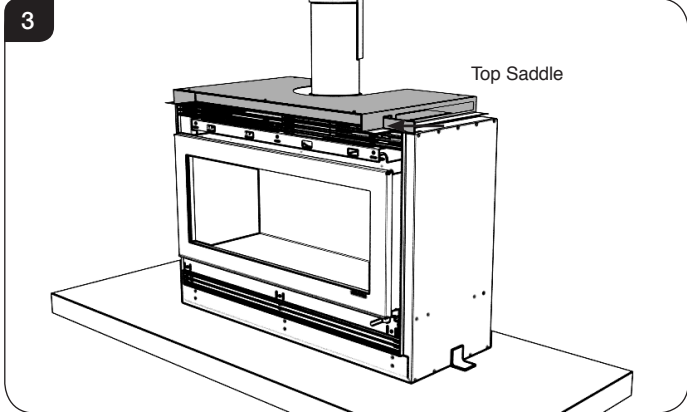

Assembly Instructions

2.3 Secure the Rear Panel to the Top Saddle, see Diagram 4.

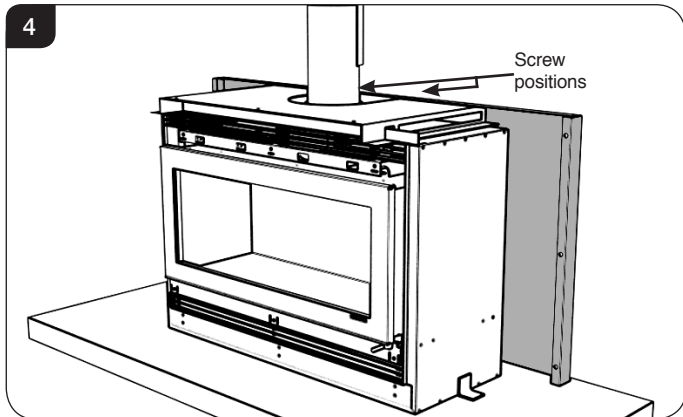

2.4 Secure the Front Panel to the top of the Saddle with 3 screws, see Diagram 5.

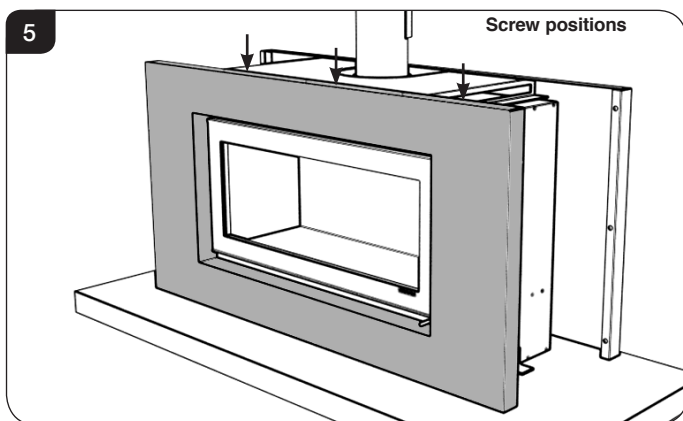

2.5 Attach the side panels internally between the front and rear using 3 screws in each side, see Diagram 6.

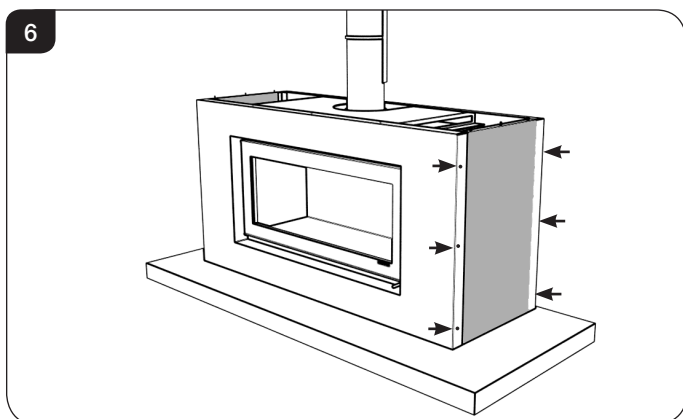

2.6 Position the Top Panel carefully without the Rear Slider Panel and press into place see Diagram 7.

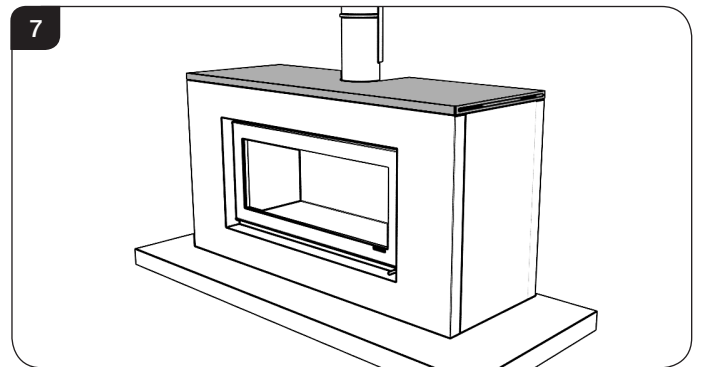

2.7 Slide the Rear Slider Plate into position in the rear aperture, see Diagrams 12 and 13.

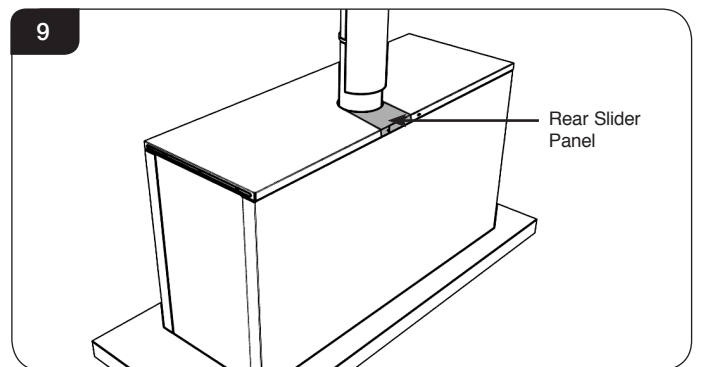
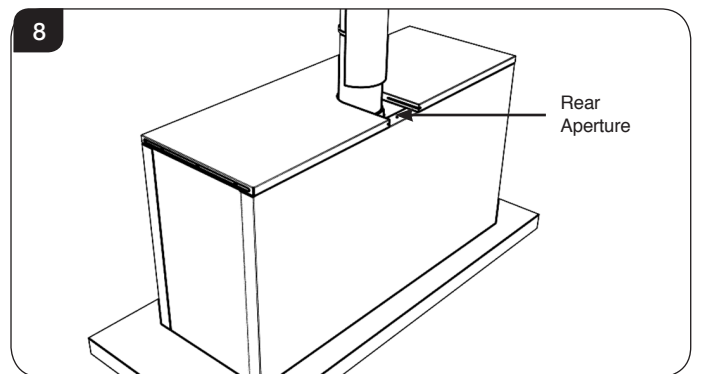

2.8 The installation is now complete.

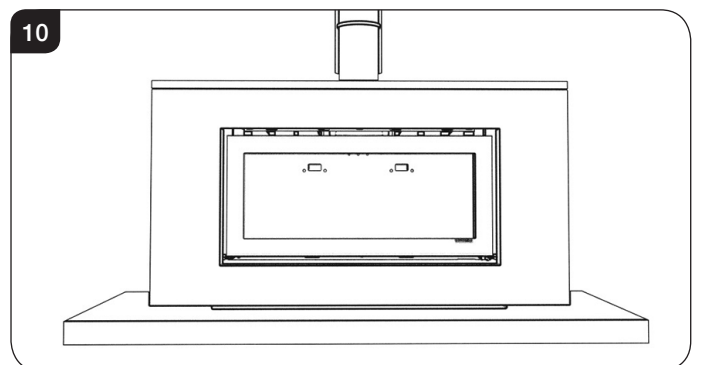

Assembly Instructions

3. Exploded Diagram - Zero Clearance Box Freestanding Cabinet

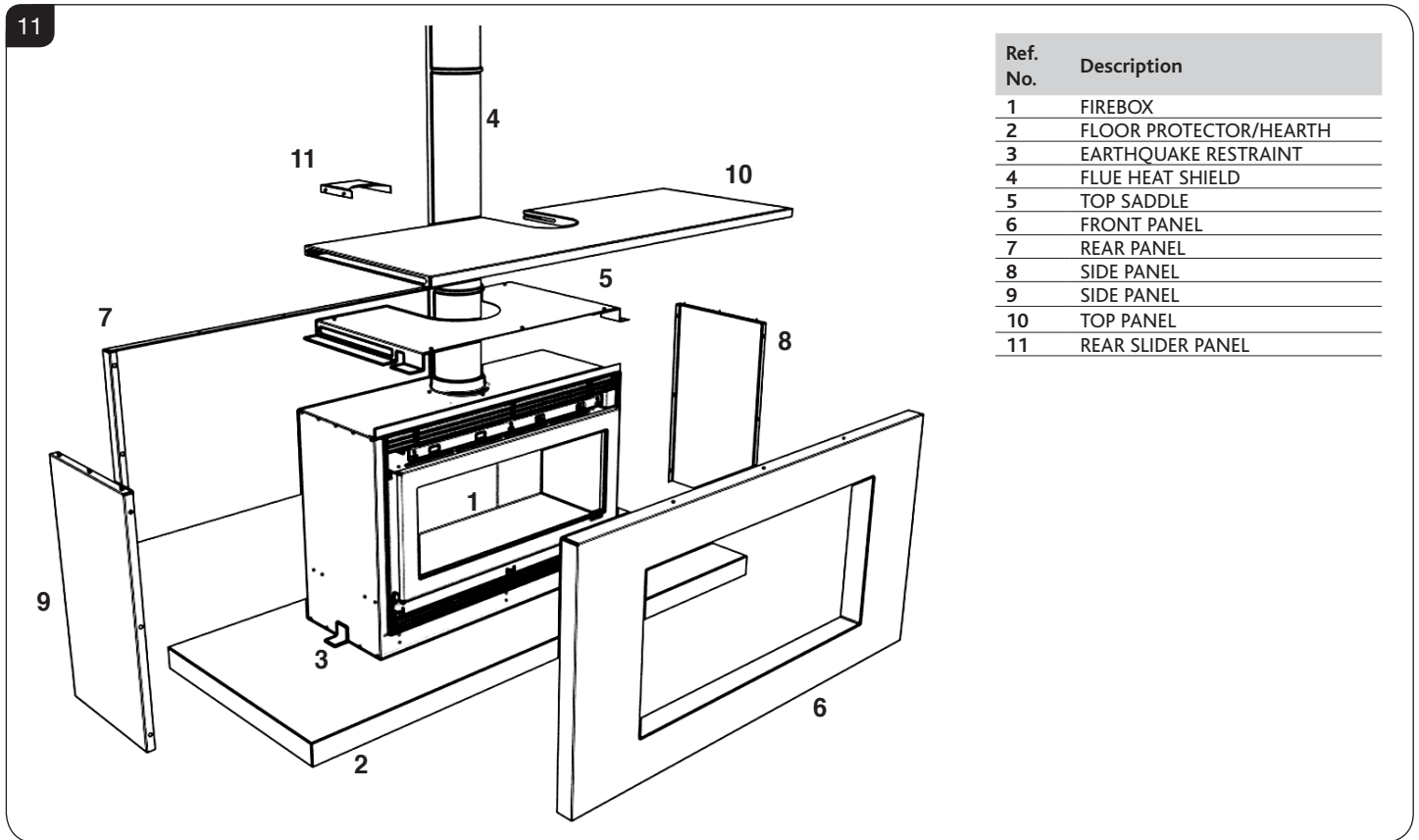

Distributed by



The Fireplace
Head Office & Showroom
12 Tawari Street Mt Eden,
Auckland ph 09 623 6996
www.thefireplace.co.nz

Manufactured by

Stovax Ltd, Falcon Road, Sowton Industrial Estate, Exeter, Devon, England EX2 7LF
Tel: (01392) 474011 Fax: (01392) 219932 E-mail: info@stovax.com www.stovax.com

E & O E

