



Fire Your Imagination

Studio

Balanced Flue with Thermostatic Remote Control



IMPORTANT:
FOR EASY TO FOLLOW,
STEP BY STEP VIDEO
INSTRUCTIONS ON HOW TO
OPERATE AND MAINTAIN YOUR
GAZCO REMOTE SYSTEM GO TO
WWW.GAZCO.TV

Instructions for Use

For use in NZ (New Zealand).

IMPORTANT

THE OUTER CASING, FRONT AND GLASS PANEL BECOME EXTREMELY HOT DURING OPERATION AND WILL RESULT IN SERIOUS INJURY AND BURNS IF TOUCHED. IT IS THEREFORE RECOMMENDED THAT A FIREGUARD IS USED IN THE PRESENCE OF YOUNG CHILDREN, THE ELDERLY OR INFIRM.

This product contains a heat resistant glass panel. This panel should be checked during Installation and at each servicing interval. If any damage is observed on the front face of the glass panel (scratches, scores, cracks or other surface defects), the glass panel must be replaced and the appliance must not be used until a replacement is installed. Under no circumstances should the appliance be used if any damage is observed, the glass panel is removed or broken.

These Instructions must be left with the appliance for future reference and for consultation when servicing the appliance. Please make the customer aware of the correct operation of the appliance before leaving these instructions with them.

Contents

Studio Balanced Flue

Covering the following models:

GAS TYPE	STUDIO 1	STUDIO 2	STUDIO 3
Natural Gas	123-024NZ	123-030NZ	123-043NZ
LPG	123-629NZ	123-653NZ	123-666NZ

Welcome

Congratulations on purchasing your Studio fire, if installed correctly Gazco hope it will give you many years of warmth and pleasure for which it was designed.

The purpose of this manual is to familiarise you with your appliance and give guidelines for its installation, operation and maintenance. If, after reading, you need further information, please do not hesitate to contact your Gazco retailer.

User Instructions	3
General.....	3
Control Options	4
Changing the Appliance Batteries	7
Cleaning the Appliance.....	8
Flame Failure Device	10
Running In	10
Servicing	10
Ventilation	10
Installation Details	10
Hot Surfaces.....	10
Appliance Will Not Light	10
Abnormal Operation	10

WARRANTY

For the length, terms and conditions of the product warranty available in your region please consult your Gazco retailer.

User Instructions

1. General

- 1.1 Installation and servicing must only be carried out by an authorised person.
- 1.2 In all correspondence, please quote the appliance type and serial number, which can be found on the data badge located on a plate under the Main Burner or on the Commissioning Check sheet.
- 1.3 **Do not** place curtains above the appliance:
You must have 300mm (1') clearance between the appliance and any curtains at either side.
- 1.4 No furnishings or other objects should be placed within 1 metre of the front of the appliance.
- 1.5 If a shelf is fitted, a distance of 400mm above the appliance is required.
- 1.6 If any cracks appear in the glass panel do not use the appliance until the panel has been replaced.
- 1.7 Do not obstruct the flue terminal in any way, i.e. by planting flowers, trees, shrubs etc. in the near vicinity, or by leaning objects against the terminal guard.
- 1.8 Do not put any objects on the terminal guard; it will lose its shape.
- 1.9 If you use a garden sprinkler, do not let quantities of water into the flue terminal.
- 1.10 This appliance is designed to operate with luminous flames and slight carbon deposits may be experienced.
- 1.11 This product is guaranteed from the date of installation, as set out in the terms and conditions of sale between Gazco and your local Gazco retailer. Please consult with your local Gazco retailer if you have any questions. In all correspondence always quote the Model Number and Serial Number.



IMPORTANT : NEVER position a television or screen above this appliance.

WARNING



In the event of a gas escape or if you can smell gas, please take the following steps:

- Immediately turn off the gas supply at the meter/emergency control valve
- Extinguish all sources of ignition
- Do not smoke
- Do not operate any electrical light or power switches (On or Off)
- Ventilate the building(s) by opening doors and windows
- Ensure access to the premises can be made

Please report the incident immediately to the National Gas Emergency Service Call Centre or Gas Supplier.

The gas supply must not be used until remedial action has been taken to correct the defect and the installation has been recommissioned by a competent person.



DO NOT OPERATE THIS APPLIANCE BEFORE READING THE INSTRUCTION BOOKLET.

DO NOT PLACE ARTICLES ON OR AGAINST THIS APPLIANCE.

DO NOT USE OR STORE FLAMMABLE MATERIALS NEAR THIS APPLIANCE.

DO NOT SPRAY AEROSOLS IN THE VICINITY OF THIS APPLIANCE WHILE IT IS IN OPERATION.

DO NOT OPERATE WITH PANELS, COVERS OR GUARDS REMOVED FROM THE APPLIANCE

DO NOT MODIFY THIS APPLIANCE.

User Instructions

2. Control Options

The appliance is operated by thermostatic remote control.

2.1 Turning the appliance On

Your remote can control the gas fire from pilot ignition through to shut down.

To turn the fire on press the OFF button and the UP button simultaneously. You hear several short signals.

The pilot and main burner ignite and the remote is now in Manual Mode:

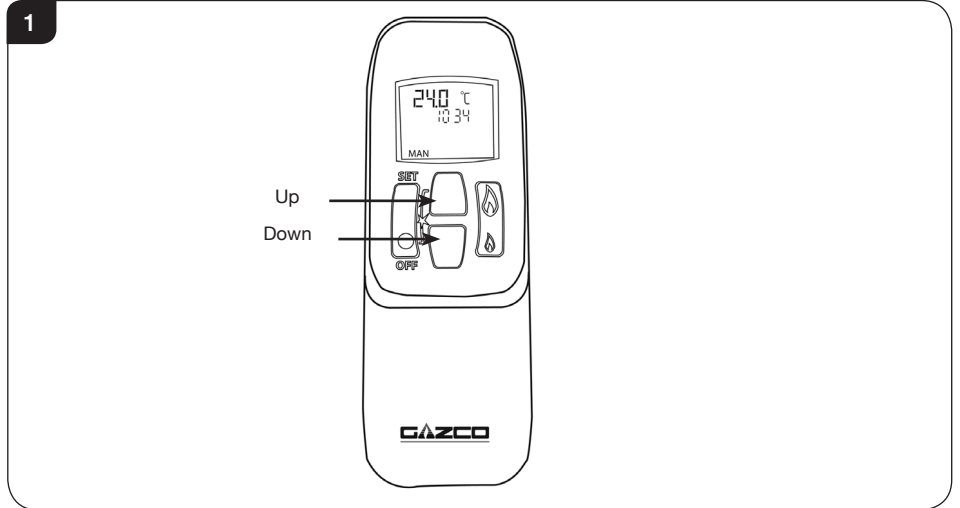

IMPORTANT: YELLOW FLAMES TYPICALLY APPEAR WHEN THE APPLIANCE HAS REACHED NORMAL OPERATING TEMPERATURE. THIS CAN TAKE UP TO 30 MINUTES.



WARNING: IF THE APPLIANCE FAILS TO LIGHT OR BECOMES EXTINGUISHED IN USE, WAIT 3 MINUTES BEFORE ATTEMPTING TO RELIGHT.

2.2 There are 3 different modes available for controlling and operating the appliance:

1. Manual Mode
2. Temp Mode (Automatic)
3. Timer Mode (Automatic)

2.3 In **MANUAL MODE** you can:

- turn on the main burner using the UP button
- regulate the flame from high to low and back
- turn off the burner leaving just the pilot burning

In **TEMP MODE (Automatic)** you can:

- set the room temperature so the thermostat in the remote automatically maintains that temperature

In **TIMER MODE (Automatic)** the fire:

- turns on and off according to the set time periods
- automatically regulates the room temperature during the set periods



NOTE: When operating the fire in Temp or Timer mode, the pilot remains lit and the fire then automatically switches on at programmed times to bring the room to the set temperature whether or not you are in the room.

NEVER LEAVE ANY COMBUSTIBLE MATERIALS WITHIN 1 METRE OF THE FRONT OF THE APPLIANCE.

Troubleshooting



IMPORTANT: In the unlikely event that the handset fails to communicate correctly with the appliance it may be necessary to turn off the gas supply at the isolation valve until any problems can be resolved.

The gas meter and isolation valve can be located outside in a meter box, under the stairs, beneath the kitchen sink or in the garage. Whilst this list is not exhaustive, it is important to be able to identify the location of the valve in case of any gas emergency.

To turn off the gas supply, simply turn the handle so the lever is at 90 degrees to the upright gas pipe.

If you smell gas, open doors and windows and never operate any electrical switches. Immediately call the Gas Emergency Services.

Switching Between Modes

- 2.4 Press the SET button to change to Temperature Mode.
Press again to change to Timer Mode.
Keep pressing to run through all operating modes. These are:
- MAN
 - DAY TEMP
 - NIGHT TEMP
 - TIMER
- and back to MAN

NOTE: MAN mode can also be reached by pressing either the UP or DOWN button.

Manual Mode

- 2.5 Press the OFF button and the UP button simultaneously. You hear several clicks and audible beeps as the fire begins the ignition process, (up to 30 seconds).

Turning the appliance Off:

Press the OFF button to turn the appliance off.

FOR SAFETY, YOU MUST WAIT 30 SECONDS BEFORE LIGHTING THE FIRE AGAIN.

Increasing the Flame Height:

Press the UP button once to increase flame height one stage. Press and hold the UP button to increase to maximum.

Decreasing the Flame Height:

Press the DOWN button once to decrease flame height one stage. Press and hold the DOWN button to decrease to minimum. At the lowest point the fire goes to 'Standby Mode' (Only Pilot lit).

 **NOTE: While pressing a button a symbol indicating transmission appears on the display. The receiver confirms transmission with a sound signal.**

Temp Mode (Automatic)

- 2.6 The display shows the current **room** temperature.

To increase or decrease the fire's output:

Press the SET button to select either the DAY TEMP or the NIGHT TEMP mode by briefly pressing the SET button.

Hold the SET button until the TEMP display flashes and then let go.

Set the desired temperature with the UP and DOWN arrows. (Minimum temperature 5C, maximum 40C or 40F to 99F when Fahrenheit is the preferred option).

Press the OFF button to stop the display flashing or wait to return to TEMP mode.

 **NOTE: If you set a temperature that is beneath the current room temperature, the fire automatically switches to PILOT (Stand by).**

If you would like the Night temperature control to turn off then decrease the temperature until [--] is displayed.

User Instructions

Timer Mode (Automatic)

2.7 There are two programmable settings you can make over a 24 hour period, P1 and P2. These are normally used to provide an early morning and evening setting for each working week:

- P1 + ● = Start Timed Setting 1
- P1 + ⤵ = End of Timed Setting 1
- P2 + ● = Start Timed Setting 2
- P2 + ⤵ = End of Timed Setting 2

2.8 P1 - Program 1 for a Timed Setting

Press the SET button until the TIMER mode is displayed.

Hold the SET button. The display flashes the current time for P1.

While the time displayed is flashing you can alter the hours and minutes set.

To set the time your fire first lights, change P1 ●

- Press the UP button to alter the hour.
- Press the DOWN button to alter the minutes in 10 minute increments.

Press SET again to move to the end setting for P1 ⤵ This is the time your Studio first shuts down:

- Press the UP button to alter the hour.
- Press the DOWN button to alter the minutes.

2.9 P2 - Program 2 for a Timed Setting

Use the same steps outlined in 2.8 to change the setting for P2.
If you have already set P1 and want to alter the setting for P2 only:

- Press the SET button until TIMER mode is displayed.
- Hold the SET button **until the display flashes the current time** for P1 ●.
- Press the SET button once again to scroll past the settings for P1 ● and P1.

With the time still flashing:

- Press the UP button to alter the hour.
- Press the DOWN button to alter the minutes.

Once all four times are set press the OFF button.

2.10 To view existing settings:

- Select Timer Mode.
- Press and briefly hold the SET button you see the start time for P1.
- Repeat the above step for the start and end of each program.

Low Battery

“BATT” is displayed on the remote when its batteries need replacement.

Setting the time

Simultaneously press the up and down buttons.

Press the up button to set the hour and the down button to set the minutes.

Press OFF to return to the manual mode or simply wait.

Setting the °C/24 Hour or °F/12 Hour clock

Press OFF and the down arrow until the display changes from °C/24 hour clock to °F/12 hour clock and vice versa.

 **If the remote is removed, lost or damaged, signals transmitted to the receiver cease. Your fire will go to standby (pilot) mode after 6 hours.**

User Instructions

3. Changing the appliance batteries

The appliance batteries are located behind the wall plate.

3.1 Undo the two screws securing the wall plate and remove, see Diagram 2.

3.2 Unclip the battery holder from the wall plate and remove the old batteries.

3.3 Correctly position the four new AA size batteries into the battery holder. Re-assemble the battery holder as shown in Diagram 3.



It is essential to use high quality batteries (Duracell or equivalent) when replacing batteries in the handset or control box.



PLEASE ENSURE NO WIRES ARE TRAPPED BEFORE REPLACING THE WALL PLATE. THE LEAD IS EASILY DAMAGED.

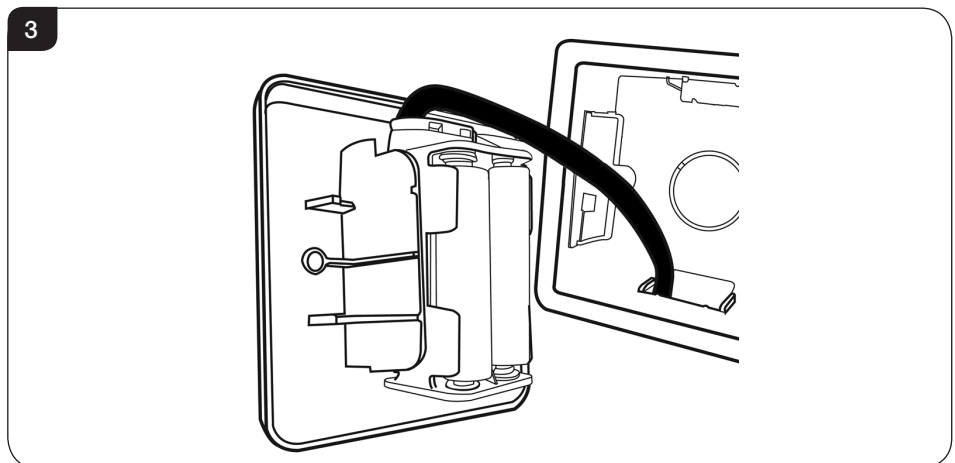
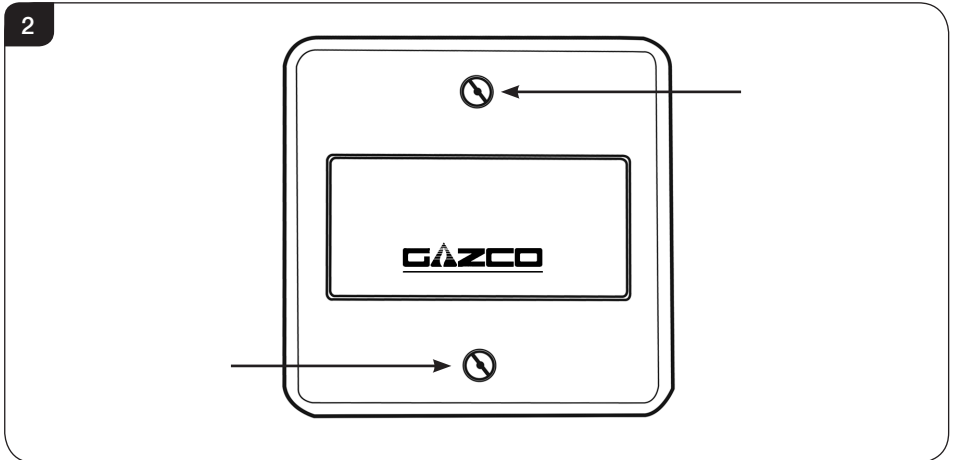

User Instructions

4. Cleaning the Appliance

4.1 Make sure the appliance and surrounds are cool before cleaning.

4.2 Use:

- A damp cloth for the painted frame.
- Soap and water to clean the glass.

Opening the Glass Window:

4.3 **Steel, Verve or Glass Frame**

If fitted with a Steel, Verve or Glass Frame, this needs to be removed first:

4.4 Lift the frame upwards off its four support brackets, see Diagram 4.

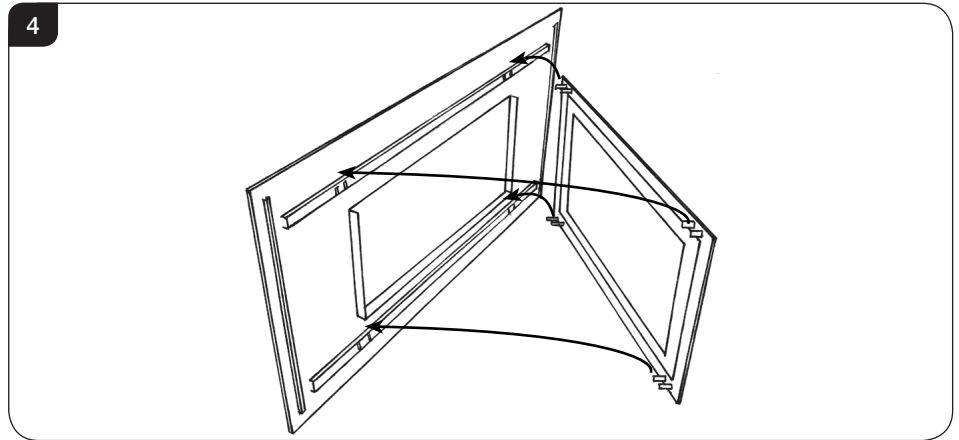

All models

4.5 To open the glass door use the hexagon key provided.

4.6 Release the window locks by moving them from shut to open towards the outer edges, see Diagram 5.

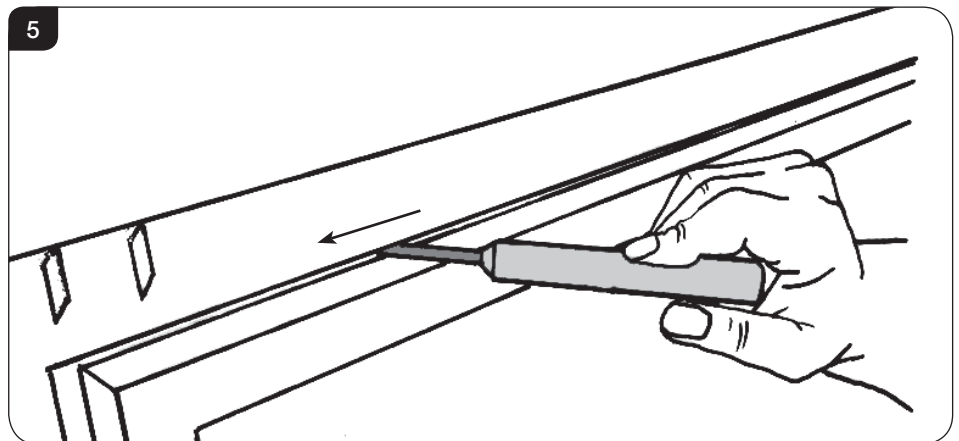

4.7 To completely remove the glass front:

4.8 Support the frame and lower it gently forward down to its natural stop position, see Diagram 6.

DO NOT EXERT PRESSURE ON THE DOOR ONCE THERE IS RESISTANCE.

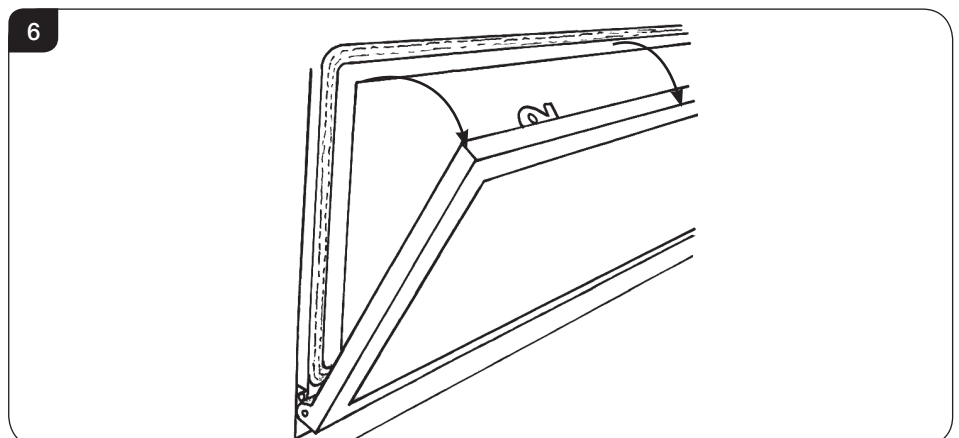

User Instructions

- 4.9 Remove the securing spring clip from the bottom-right of the window frame, see Diagram 7.

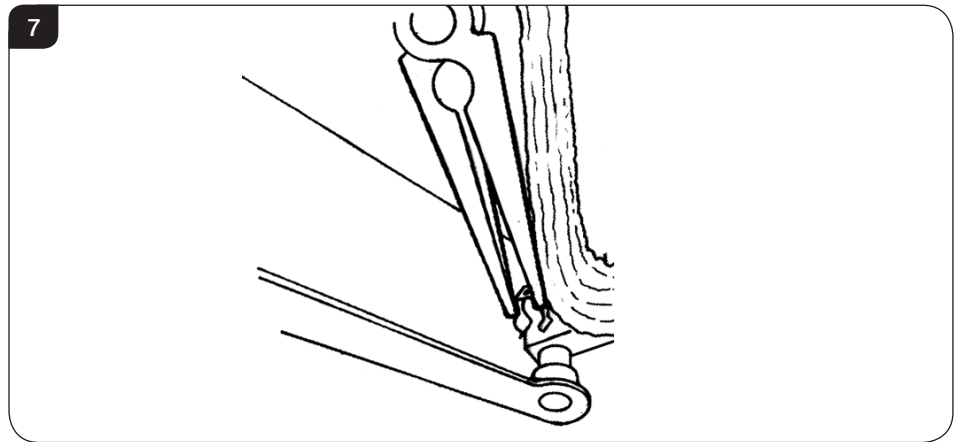

- 4.10 With the window frame in an upright position slide the frame to the left so that it comes off the left hinge pin, see Diagram 8 (1).

- 4.11 Still keeping the frame upright drop the left side down and forward slightly, see Diagram 8 (2).

- 4.12 Slide the frame to the right so it comes off the right hinge pin. The window frame should now be free.

- 4.13 Refit the Window Frame Assembly in reverse order.

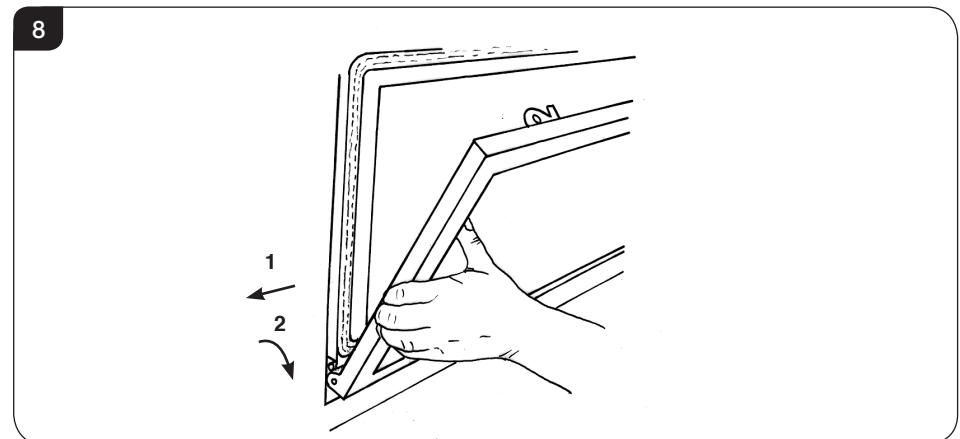

When closing the door ensure the door catches are fully engaged.



UNDER NO CIRCUMSTANCES SHOULD THE APPLIANCE BE USED WITHOUT THE CATCHES HOLDING THE DOOR IN PLACE.

User Instructions

5. Flame Failure Device

- 5.1 This is a safety feature incorporated on this appliance which automatically switches off the gas supply if the pilot goes out and fails to heat the thermocouple.

IF THIS OCCURS DO NOT ATTEMPT TO RELIGHT THE APPLIANCE FOR 3 MINUTES.

6. Running In

- 6.1 During initial use of a new GAZCO appliance a strong odour will be encountered as various surface coatings become hot for the first time. Although these odours are harmless it is recommended that the appliance is operated on maximum for 4 to 8 hours in order to fully burn off these coatings. After this period the odours should then disappear.

If the odours persists, please contact your installer for advice.

- 6.2 During the first few hours of burning there may be discolouration of the flames. This will also disappear after a short period of use.

7. Servicing

- 7.1 The appliance must be serviced every 12 months by a authorised person. In all correspondence always quote the Model number and the Serial number which may be found on the Commissioning Checklist (Page 3).

8. Ventilation

- 8.1 This appliance requires no additional ventilation.

9. Installation Details

- 9.1 The installer should have completed the commissioning sheet at the front of the installation book. This records the essential installation details of the appliance. In all correspondence always quote the Model number and Serial number.

10. Hot Surfaces

- 10.1 Parts of this appliance become hot during normal use.
- 10.2 Regard all parts of the appliance as a working surface.
- 10.3 Provide a suitable fire guard to protect young children and the infirm.

11. Appliance will not light

If you cannot light the Studio:

- 11.1 Check and change the batteries in the remote handset.
- 11.2 Check and change the appliance batteries (see Section 3).
- 11.3 Consult your Gazco retailer or installer if the Studio still does not light.

12. Abnormal Operation

- 12.1 If main burner does not light but pilot stays on, shut down the appliance and contact your dealer.
- 12.2 If excessive carbon on logs or glass contact your dealer for service.

Distributed by:



Head Office & Showroom
12 Tawari Street
Mt Eden, Auckland, New Zealand
+649 623 6990
thefireplace.co.nz

Manufactured by

Gazco Limited, Osprey Road, Sowton Industrial Estate, Exeter, Devon, England EX2 7JG
Technical Customer Services (01392) 261950 Fax: (01392) 261951
E-mail: technicalservices@gazco.com

A member of the Stovax Group



PR2410